

# Toroidal transformer type 27612

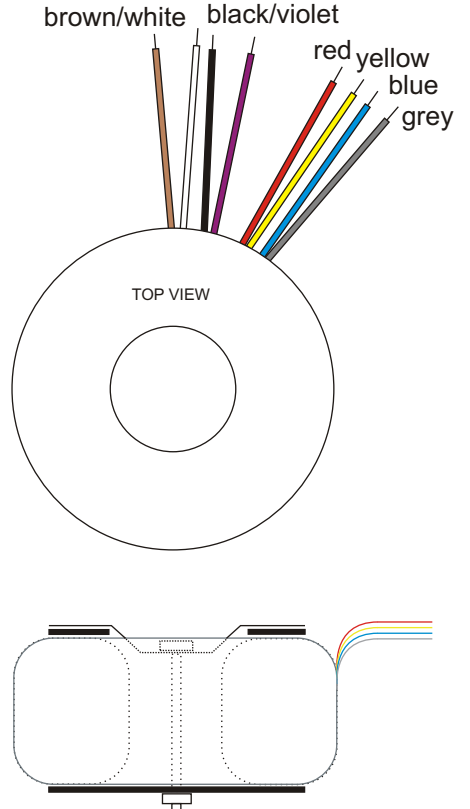
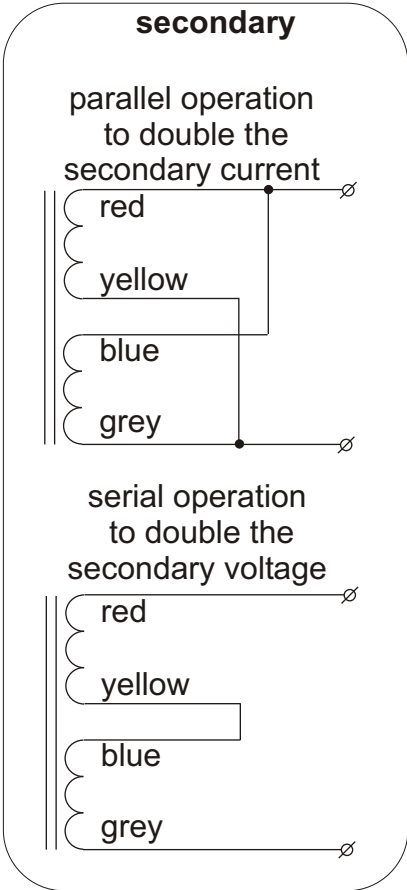
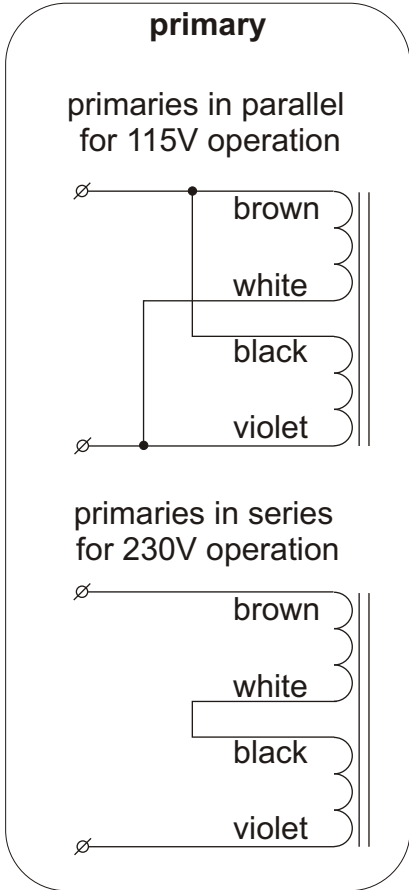
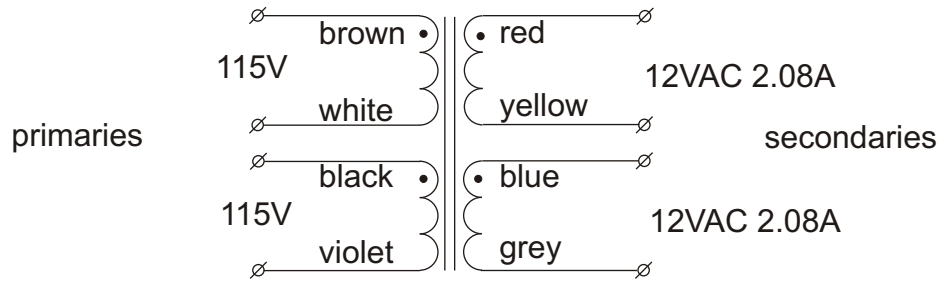

Diameter approx. 80mm  
 Height approx. 33mm  
 Weight approx. 0.76kg  
 Height and weight are measured without mounting materials  
 All leads are flexible and approx. 200mm long

Supplied mounting materials:  
 1 metal washer  
 2 neoprene washers  
 1 bolt with nut

according to EN61558. With CE and UL/CSA approvals  
 UL filenumber E311200.  
 RoHS-compliant

Type number	primary	secondaries voltage	current
27612	2x115V	2x 12V	2.08A

All voltages are under full ohmic load  
 Regulation : 11.8%

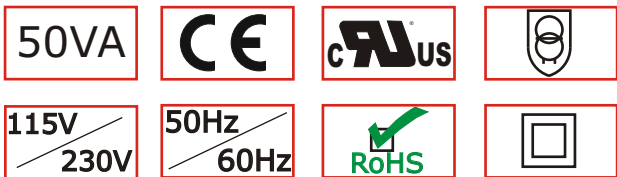

P/N AMP-0050012  
 TYPE 27612  
 BATCH 00000  
 MADE IN CHINA

CE 50/60Hz  
 cULUS E311200

PRI. 2x 115VAC BROWN-WHITE / BLACK-VIOLET  
 SEC. 2x 12VAC 2.08A RED-YELLOW / BLUE-GREY

	Industrieweg 14 7161BX NEEDE The Netherlands  P O - B o x 2 7 NL-7160AA NEEDE The Netherlands Tel.+31 (0)545 283456 Fax+31 (0)545 283457 info@amplimo.nl http://www.amplimo.nl	HB	Nov 2008	<b>27612</b> P/N: AMP-0050012
	© Copyright Amplimo BV			